

24 Series 4IN1 Driver

Basic Installation Instructions v1.4

1. Applicable Drivers:

The types of applicable drivers are as follows:

	Type	Product Name
1	S08-SMD24B20-00	SMD-30/30/30/30-XS 4IN1 Driver
2	S08-SMD24C20-00	SMD-30/30/30/30-XS 4IN1 Driver
3	S08-SME24C20-00	SMD-30/30/30/30-XS 4IN1 Driver

2. Driver Interface Instructions

● 24B (Top View)

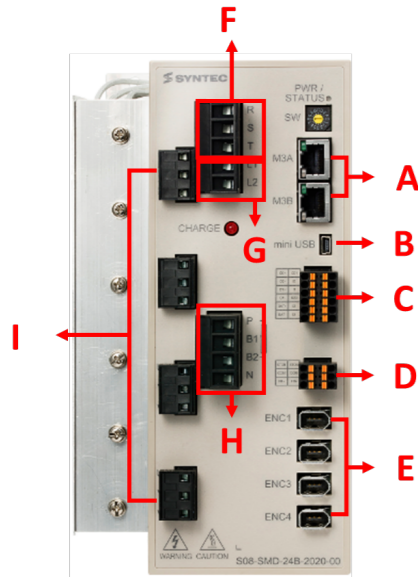

● 24C (Top View)

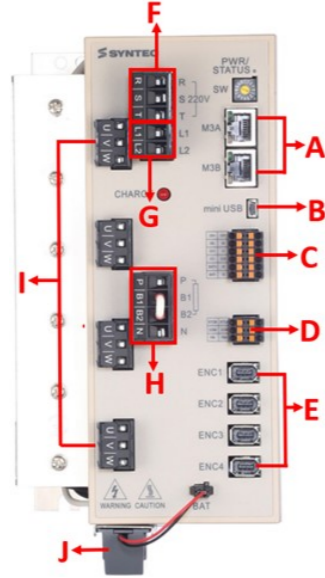

A	M3/ECAT Serial Communication Port	Connect to the host controller and the next driver, 100Mbps serial communication
B	Mini USB Port	Connect to personal computer
C	I/O Signal Port	Connect to I/O equipment (i.e. the emergency stop, indicator lights, etc.)
	External Battery Port	Connect the absolute encoder power supply battery (dry cell battery box) here
D	STO Signal Port	STO interface; 2 sets of safety inputs and a set of safety function feedback.
E	Encoder Feedback	From top to bottom are the 1st port to the 4th connecting to motor encoders.
F	External Power Supply	Connect to 3-phase electrical power 220V (RST)
G	Control Power	If there are safety requirements, the controlled source can be independently supplied from L1 & L2 and connect to single-phase AC 220V. The input voltage must be the same as RST.

H	Regenerative Resistor	2 connection methods, optional: 1. Connect the external regenerative resistor to P & B2 2. The built-in brake is to short circuit B1 and B2
I	Machine Power Supply	Connect to motor and supply power (UVW)
J	External Power Supply	Install the lithium battery for power supply of the absolute encoder

3. Controller Specifications (Unit: mm)

● 24B

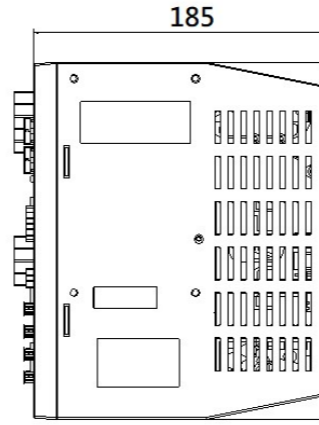
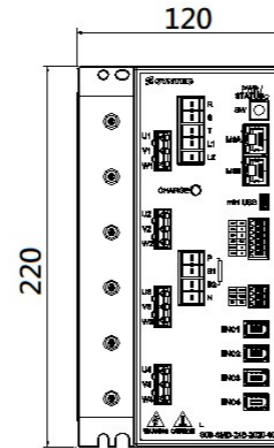

● 24C

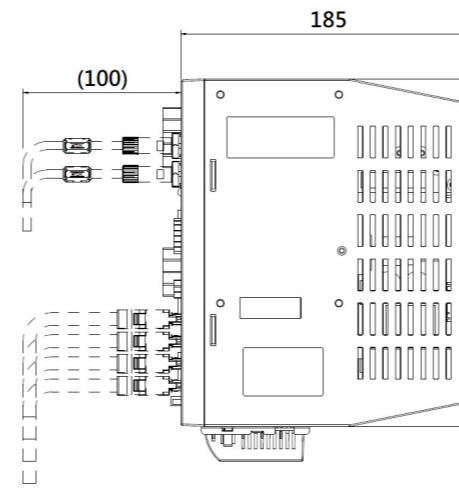
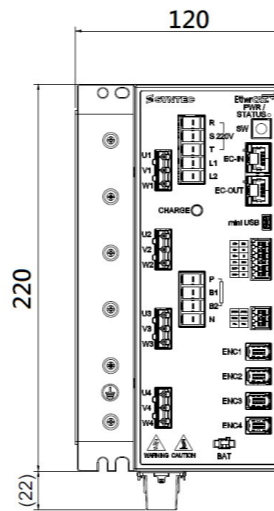

4. Installation Specifications (Unit: mm)

● 24B Front View

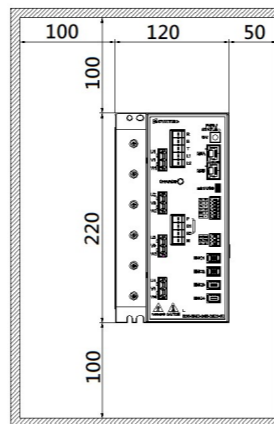

● 24B Side View

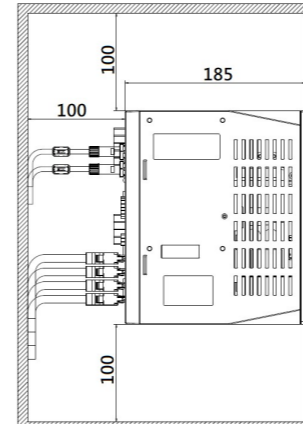

● 24C Front View

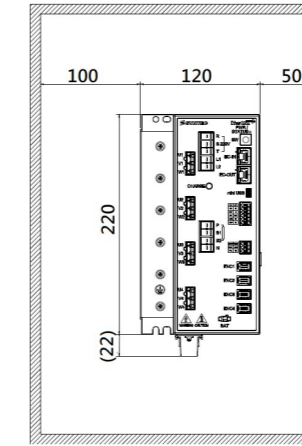

● 24C Side View

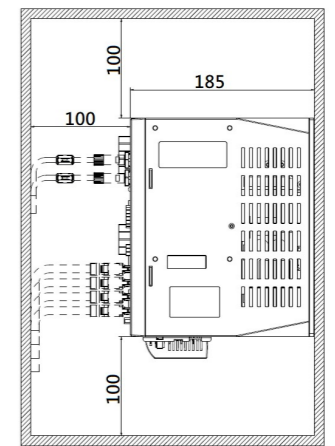

5. Mounting Hole Specifications (Unit: mm) Please install with M5 screws.

● 24B /24C

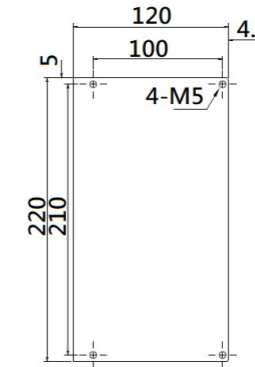

6. Basic Wiring Diagram

- Please Confirm whether the wiring of the U, V, W terminals output to the motor is correct, otherwise it may cause reversal or abnormality, and the encoder must be adjusted again.
- In case the use of independent controlled source, please connect the sources (L1, L2) of the control plate to either of the three RST terminals before the magnetic contactor (MC).
- The default settings of B1 and B2 are short circuit with built-in braking resistors. If the processing requires a high load factor, it is recommended removing the short circuit wiring and apply an external high wattage braking resistor between P and B2.

● 24B/24C

Correct wiring method

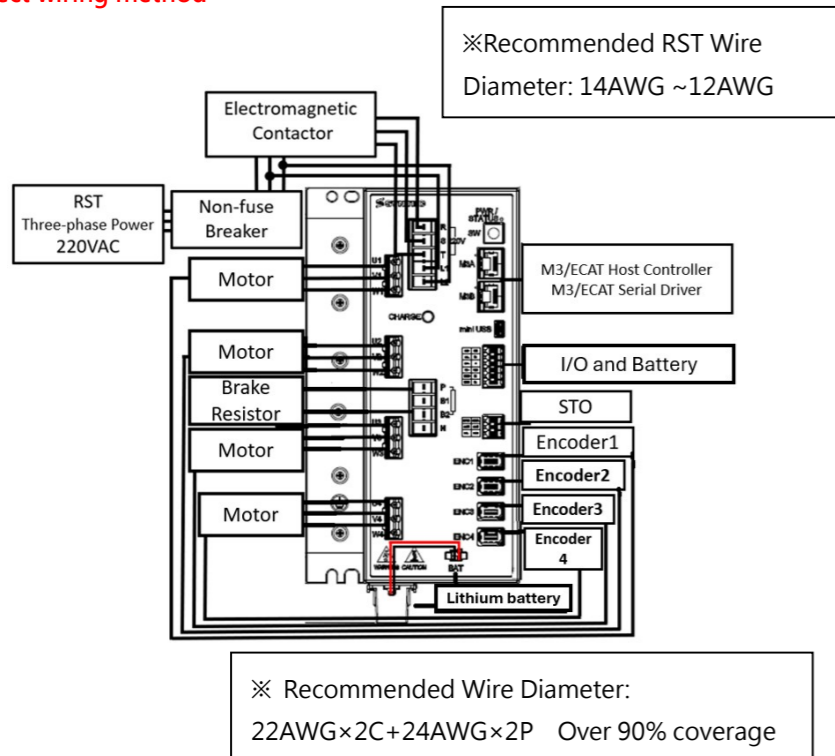

(3) Since the electronic transformer outputs a non-sinusoidal wave, failure to connect according to the wiring method of the electronic transformer manufacturer may cause drive failure.

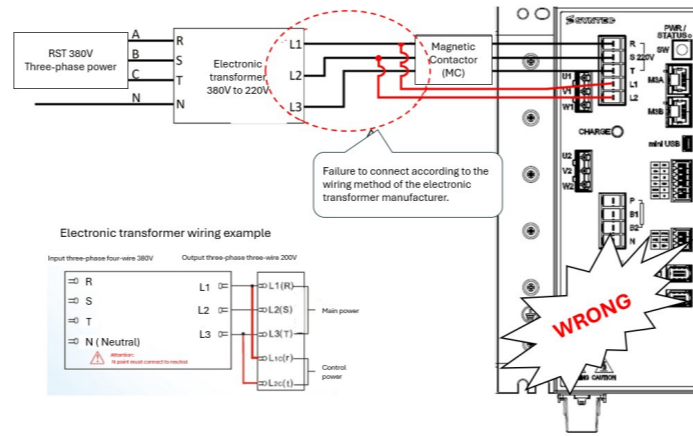

Suggestion :

- If the machine does not have safety requirements (use MC to cut off the main circuit power supply), connect the driver control power supply L1/L2 is not required. Only need to connect the transformer L1/L2/L3 to the driver R/S/T.
- Since electronic transformers have different designs from different manufacturers and the output is not a three-phase AC sine wave, parameter Pn-036 (three-phase → single-phase) can be adjusted to avoid alarms caused by abnormal power supply detection.

8. Driver Specifications

Type	S08-SMD24B20-00 / S08-SMD24C20-00/ S08-SME24C20-00	
Input Voltage	MAIN:AC 3PH 200~230V 50/60Hz CONT.:AC 1PH 200~230V 50/60Hz	
Input Current	MAIN:22A CONT.:0.25A	
Output Voltage	Axis1~Axis4	AC 3PH 0~230V 0~400Hz
Rated Output Current	Axis1~Axis4	7.6A
Rated Power	Axis1~Axis4	1kW
Terminal Specifications	RST · PBN	Wire Specification: 12 AWG Rated Torque : 0.51 N·m
	U ₁ V ₁ W ₁ ~U ₄ V ₄ W ₄	Wire Specification: 16-14 AWG Rated Torque : 0.6 N·m
	I/O Signal Port	Wire specifications : 28~16 AWG
Environment Condition	TN System ⁽¹⁾ Allowable voltage deviation : -15% ~ +10% Allowable frequency deviation : -5% ~ +5%	
	Ambient Temperature	Operating: 0 to 55°C (Without condensation. With de-rating above 40°C.) Storage/Transport: -20 to 65°C
Environment Condition	Ambient Humidity	Operation: Below 90% RH (without condensation) Storage / Transport: Below 90%RH (without condensation)
	Surrounding Area	Indoor (Avoid direct sunlight), avoid corrosive gas, avoid flammable gas.
	Height	Operating/Storage Altitude (Max.) : 1,000 meters (With derating, usage is possible at the altitude between 1,000 m and 2,000 m.) Transporting Altitude (Max.) : 10,000 meters
	Vibration	5.9 m/s ²
	Pollution Degree	2
	IP Level	IP20
	Frame Size W × H × D mm	220 x 185 x 120
	Weight	3.95Kg

Wrong wiring method

(1) Connecting any two sets of three-phase 380V single-phase electricity with different phases to the driver will cause the driver to withstand voltages exceeding 220V and cause malfunctions.

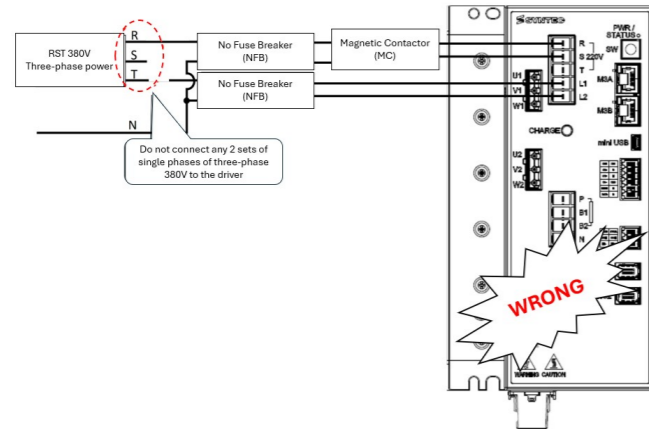

(2) Since the voltage difference between the two sets of single-phase 220V cannot be determined, the driver may be subjected to a voltage exceeding 220V and cause a malfunction.

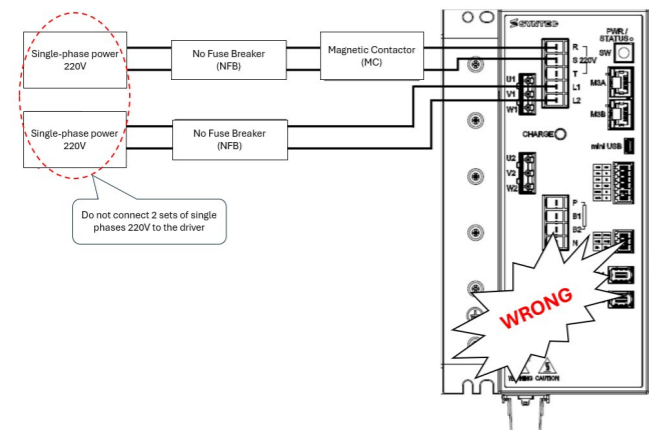

7. Interface Configurations

Please notice the value and polarities of voltages.

● Encoder Feedback Arrangement

Encoder Feedback	PIN	SIGNAL
	1	5V
	2	GND
	3	BAT+
	4	BAT-
	5	D+
	6	D-

● M3/ECAT Serial Port Arrangement

M3/ECAT	PIN	SIGNAL
	1	TX+
	2	TX-
	3	RX+
	4	NC
	5	NC
	6	RX-
	7	NC
	8	NC

● I/O Signal Port

I/O Port	PIN	SIGNAL
	1	OO+
	2	OO-
	3	O1+
	4	O1-
	5	BAT+
	6	BAT-
	7	SDI COM01
	8	I0
	9	I1
	10	SDI COM23
	11	I2
	12	I3

● Station Number Settings

Station No. Setting	PIN	SIGNAL	PIN	SIGNAL
	0	N/A	8	Station No.8
	1	Station No.1	9	Station No.9
	2	Station No.2	A	Station No.10
	3	Station No.3	B	Station No.11
	4	Station No.4	C	Station No.12
	5	Station No.5	D	Station No.13
	6	Station No.6	E	Station No.14
	7	Station No.7	F	Station No.15

● STO Signal Port

STO	PIN	SIGNAL	PIN	SIGNAL
	1	STO-A	2	STO-B
	3	STO-COM	4	STO-COM
	5	STO-FB+	6	STO-FB-

Notice : Contact capacity of output is DC30V, 200mA. Do not use in overload condition.

NOTE :

TN System : The neutral point of the power system is grounded directly to earth, and the exposed metal components are grounded by protective earthing conductors.